

Acoustic Slab

An easy-to-fit, semi-rigid slab for acoustic partition wall and floor applications

Rockwool Acoustic Slab is a high quality resin bonded semi-rigid slab, designed to combine optimum acoustic and fire performance with easy fitting into both partition and floor constructions.

Tests have shown that by fully filling voids in both metal and timber stud partitions, Acoustic Slab significantly improves levels of sound reduction across all frequencies compared to lightweight board.

Advantages

- Excellent acoustic absorption
- Simple and fast installation
- Optimum dimensions to suit metal and timber stud partitions
- Fire safe
- Suitable for continued performance - no sagging or slumping

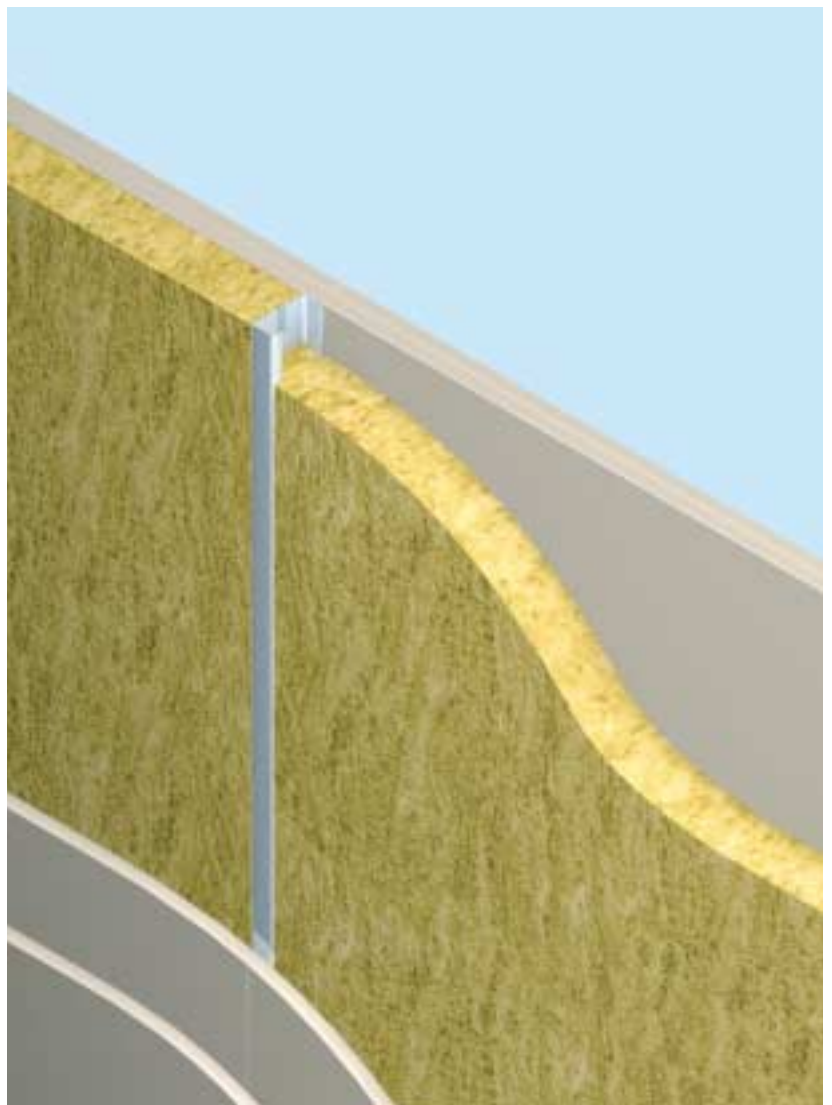

Standards and approvals

Rockwool Acoustic Slab complies with the requirements of BS EN 13162: 2001 Thermal Insulation products for buildings Factory made mineral wool (MW) products specification.

Description

Acoustic Slab is designed specifically to suit installation between metal and timber studs at 400 and 600 mm centres. The dimensions of the product have been optimised accordingly.

Dimensions

Standard size: 1200 x 590 mm

Thicknesses: 47 and 67 mm

Performance and properties

Environment

No CFCs, HFC's or HCFCs are used in the manufacture of Rockwool materials.

Fire

Acoustic Slab will achieve A1 when tested to EN 13501-1 Euro classification.

Applications

1 Metal stud partitions

Acoustic Slab has been tested within a wide variety of metal stud partition structures, and provides a high level of airborne sound insulation.

Figure 1 Typical lightweight office partition

Weighted sound reduction index R_w 43 dB

Fire resistance 30 minutes

Studs 50 mm width @ 600 mm centres

Facings One layer of 12.5 mm Lafarge Standard Wallboard both sides

Insulation 47 mm Acoustic Slab

Report No BTC 10192A

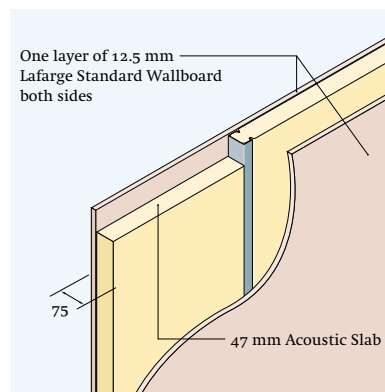

Figure 1

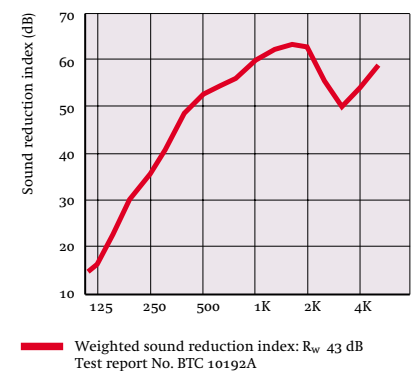

Figure 2 Typical Hotel bedroom wall partition

Weighted sound reduction index R_w 54 dB

Fire resistance 30 minutes

Studs 70 mm width @ 600 mm centres

Facings One layer of 15 mm Lafarge sound resisting Wallboard one side. Other side one layer of 15 mm sound resisting Wallboard fixed to resilient bar.

Insulation 67 mm Acoustic Slab

Report No BTC 10189A

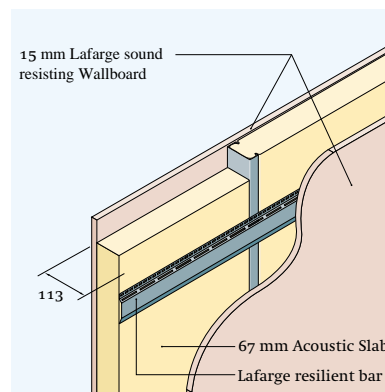

Figure 2

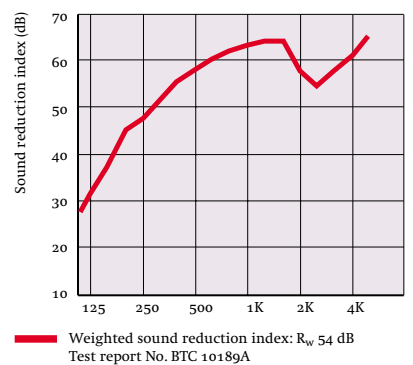

Figure 3 Separating wall/partition

Weighted sound reduction index R_w 55 dB

Fire resistance 60 minutes

Studs 70 mm width @ 600 mm centres

Facings Two layers of 12.5 mm Lafarge Standard Wallboard both sides

Insulation 67 mm Acoustic Slab

Report No BTC 10191A

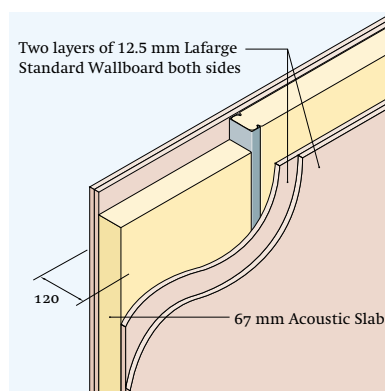
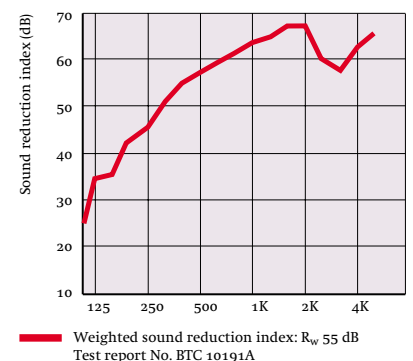

Figure 3



Absorption coefficients

The structure of Rockwool makes it an ideal product for use as a sound absorber. The absorption coefficients are characteristically high over a wide range of frequencies (see table below).

Material	Thickness (mm)	Mounting	Frequency (Hz)					
			125	250	500	1K	2K	4K
Acoustic Slab	47	Direct	0.20	0.50	0.85	1.00	1.00	1.00
Acoustic Slab	67	Direct	0.30	0.70	1.00	1.00	1.00	1.00

Test report numbers BTC 10264A, BTC 10265A

Partition structure

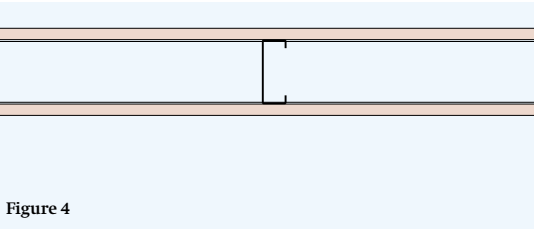
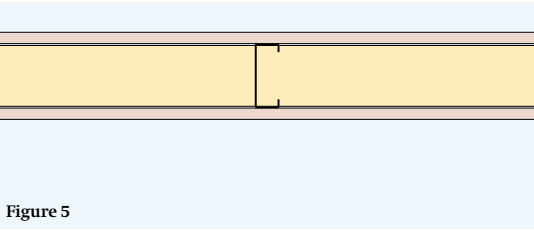
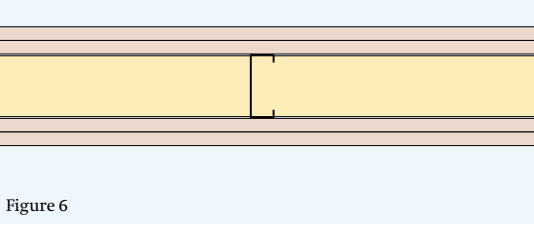
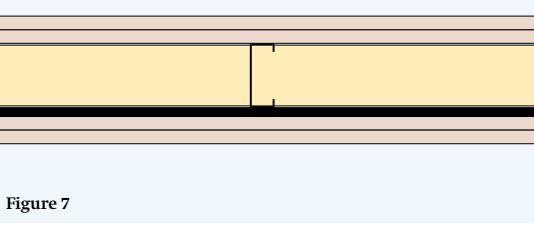
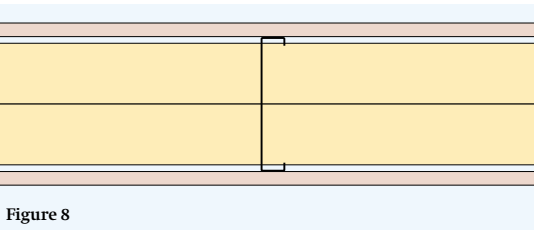
Partition structure	Specification	Nominal thickness (mm)	Weighted sound reduction index (R _w dB)	Fire Resistance (minutes)
 <p>Figure 4</p>	<p>Studs 70 mm width @ 600 mm centres. Facings One layer 12.5 mm Lafarge Standard Wallboard both sides No insulation</p>	95	36	30
 <p>Figure 5</p>	<p>As above with 67 mm Acoustic Slab Report No BTC 10190A</p>	95	44	30
 <p>Figure 6</p>	<p>Studs 70 mm width @ 600 mm centres. Facings Two layers of 15 mm Lafarge sound resisting Wallboard both sides Insulation 67 mm Acoustic Slab Report No BTC 10183A</p>	132	57	90
 <p>Figure 7</p>	<p>Studs 70 mm width @ 600 mm centres. Facings Two layer 15 mm Lafarge sound resisting Wallboard one side. Other side two layers of 15 mm sound resisting Wallboard fixed to resilient bar. Insulation 67 mm Acoustic Slab Report No BTC 10187A</p>	143	63	90
 <p>Figure 8</p>	<p>Studs 146 mm width @ 600 mm centres. Facings One layer 15 mm Lafarge Firecheck Wallboard both sides Insulation 2 layers of 67 mm Acoustic Slab Report No BTC 10193A</p>	176	53	60

2 Timber stud partitions

Acoustic Slab performs effectively as an infill between timber studs. Note: NHBC require a minimum of 38 dB for specific internal partitions.

Figure 9 Lightweight domestic timber stud partition

Weighted sound reduction index R_w 39 dB

Fire resistance 30 minutes

Studs 50 x 50 timber studs @ 600 mm centres

Facings 12.5 mm plasterboard both sides

Insulation 47 mm Acoustic Slab

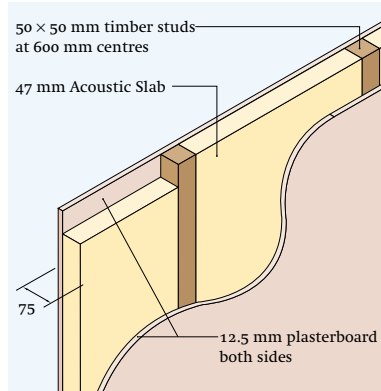

Figure 9

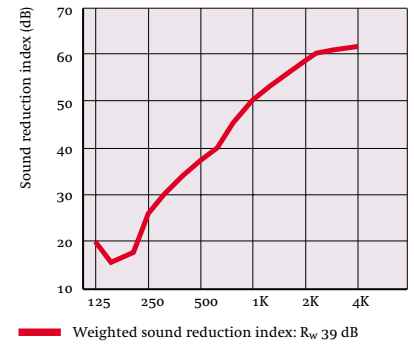

Figure 10 Typical lightweight office partition adjacent to factory

Weighted sound reduction index R_w 46 dB

Fire resistance 60 minutes

Studs 44 x 75 timber studs @ 600 mm centres

Facings Two layers of 12.5 mm Lafarge Standard Wallboard both sides

Insulation 67 mm Acoustic Slab

Report No L/1944/A/7

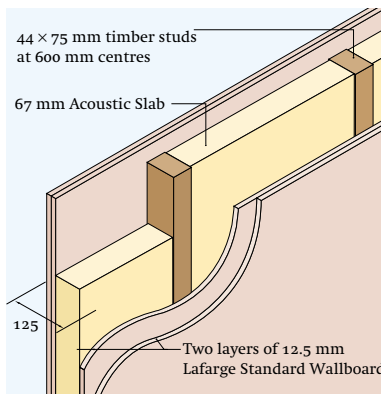

Figure 10

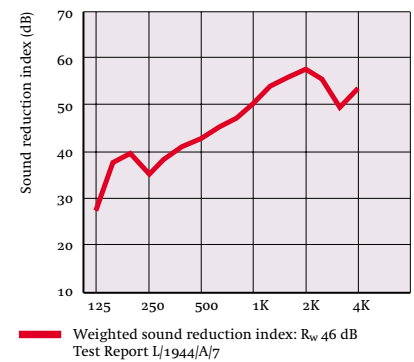

Figure 11 Non-loadbearing separating wall construction

Weighted sound reduction index R_w 59 dB

Studs 38 x 57 timber studs @ 400 mm centres

Facings Two layers of 9.5 mm plasterboard both sides

Insulation Two layers of 47 mm Acoustic Slab

Report No RI Test Report P7

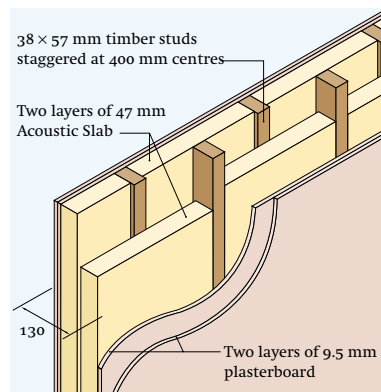
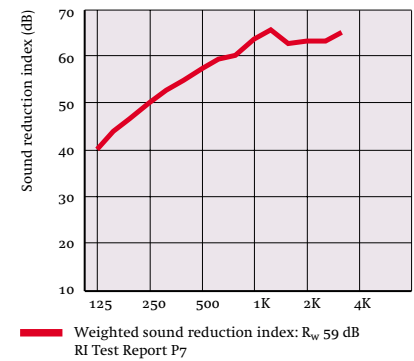

Figure 11



Separating walls

Figure 12 Timber frame separating wall

Acoustic Slab used to provide sound insulation to comply with the Building Regulations.

Acoustic Slab is fitted between the studs on one side of the separating wall only. The construction shown complies with the Requirements of Approved Document E/2/3 of the National Building Regulations.

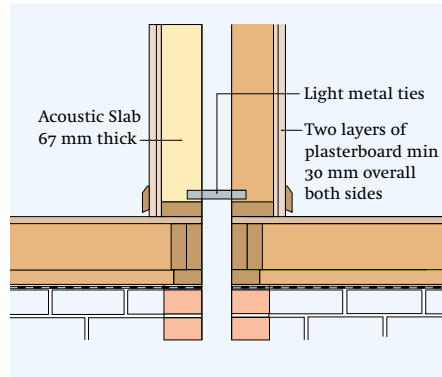

Figure 12 Acoustic Slab as acoustic insulation to timber framed separating wall

Figure 13 Upgrading existing separating walls to comply with Approved Document E

Single brick Separating wall with access limited to one side.

Acoustic Slab is fitted between timber studs on one side of the wall only. The construction should be fixed to the floor and ceiling only and must not be fixed to or touch the separating wall.

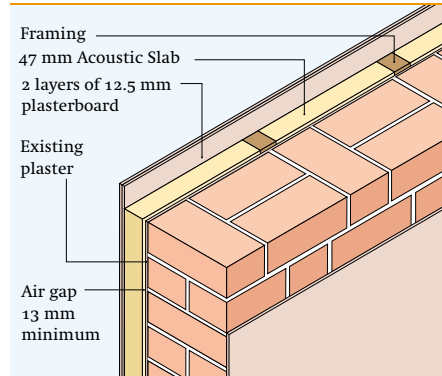

Figure 13 Acoustic Slab as acoustic insulation to single brick separating wall

Upgrading timber joisted floors

Figure 14 Upgrading an intermediate timber floor to comply with the requirements of the National Building Regulations

The Rockwool Acoustic Floor System comprises Rockwool Rigid Slabs bonded to special high density cement particle board, with Acoustic Slab inserted into floor cavity.

Fire resistance 60 minutes

Sound reduction R_w 53 dB

Impact sound pressure level $L_{n,w}$ 62 dB

AIRO Report No L/2388/3

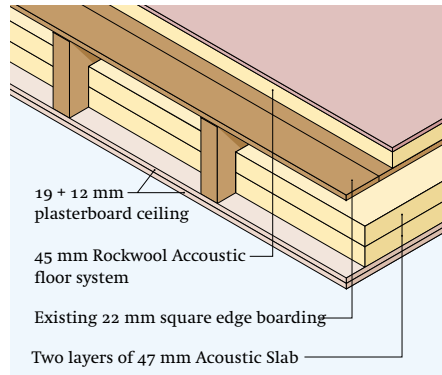

Figure 14 Rockwool Acoustic Floor System

Figure 15 Upgrading an intermediate timber floor within a dwelling

The construction includes a hardboard layer over square edge floorboards.

Fire resistance 60 minutes

Approximate sound reduction 43 dB

Note that this treatment will slightly improve the impact noise.

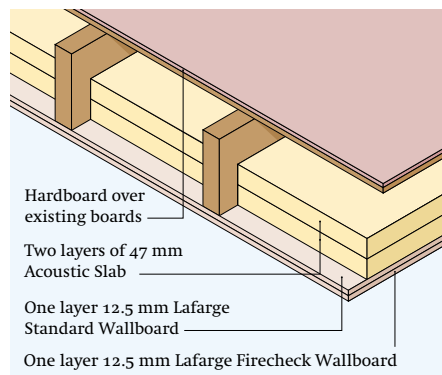

Figure 15 Existing timber joisted floor with Acoustic Slab

Work on site

Fixing

Acoustic Slabs are light and easy to cut with a sharp knife.

A Metal stud partitions

For installation between metal studs, at 600 mm centres, insert Acoustic Slabs using the standard 590 mm width, and friction fit.

For metal studs at 400 mm centres cut the Acoustic Slab to size across the 1200 mm length and similarly friction fit ensuring that all horizontal joints are tightly butted.

The standard 47 and 67 mm thicknesses are designed to accommodate 50 and 70 mm metal studs respectively.

B Timber studs

For studs at 600 mm centres the product should be cut across the 590 mm width, where appropriate and friction fitted. Similarly, for studs at 400 mm centres, the product should be cut across the 1200 mm dimension and friction fitted.

When cutting, slightly overcut to ensure a tight fit. Ensure that all horizontal joints are tightly butted. The insulation thickness must correspond to the depth of the stud used. (i.e. 47 mm Acoustic Slab with 50 mm studs and 67 mm with 70/75 mm studs).

Handling and storage

Rockwool Acoustic Slabs are shrink wrapped in polyethylene for short term protection. For long term protection they should be stored indoors or under a waterproof covering.

Workmanship

To achieve satisfactory sound reduction, it is important to ensure that the separating wall or partition is correctly constructed. Acoustics Slabs must be tightly butted at joints, leaving no gaps.

Typical specification clause

Infill within stud partition

The acoustic infill is to be Rockwool Acoustic Slab, 47/67* mm thick, installed to a tight fit between the timber/metal* studs. Chasing of the acoustic infill for services will not be permitted without the prior consent of the Supervising Officer.

*Delete as required.

Health and safety

A COSHH Data sheet is available from Rockwool's Marketing Services Department.

Current HSE 'CHIP' Regulations and EU Directive 97/69/EC confirm that Rockwool fibres are not classified as a possible carcinogen.

Maintenance

Once installed Acoustic Slab needs no maintenance and will neither slump nor sag during the lifetime of the partition or floor structure.

Proprietary materials

Information on Lafarge Standard Wallboard, sound resisting Wallboard and Resilient Bar is available from Lafarge Plasterboard Ltd.

Tel 01275 377789

Technical Helpline

Technical advice relating to Acoustic Slab is available from the Rockwool Technical Helpline Services Department on 0871 222 1780.

Rockwool Limited reserves the right to alter or amend the specification of products without notice as our policy is one of constant improvement.

The information contained in this data sheet is believed to be correct at the date of publication. Whilst Rockwool will endeavour to keep its publications up to date, readers will appreciate that between publications there may be pertinent changes in the law, or other developments affecting the accuracy of the information contained in this data sheet.

The above applications do not necessarily represent an exhaustive list of applications for Acoustic Slab. Rockwool Limited does not accept responsibility for the consequences of using Acoustic Slab in applications different from those described above. Expert advice should be sought where such different applications are contemplated, or where the extent of any listed application is in doubt.

WILHAMS

Wilhams Insulation Far East Sdn Bhd (340166M)
15 & 17 Jalan U5/23, Seksyen U5,
Mah Sing Integrated Industrial Park
40150 Shah Alam, Selangor Darul Ehsan, Malaysia
Tel: 603-7846 6728 Fax: 603-7846 6540
E-mail: wife@lm.net.my