



**ROCKWOOL**  
FIRESAFE INSULATION

# Conlit<sup>®</sup> Ductwork System

Single layer fire protection for rectangular, circular and oval ducts

Specified with confidence

Installed quickly, simply and reliably

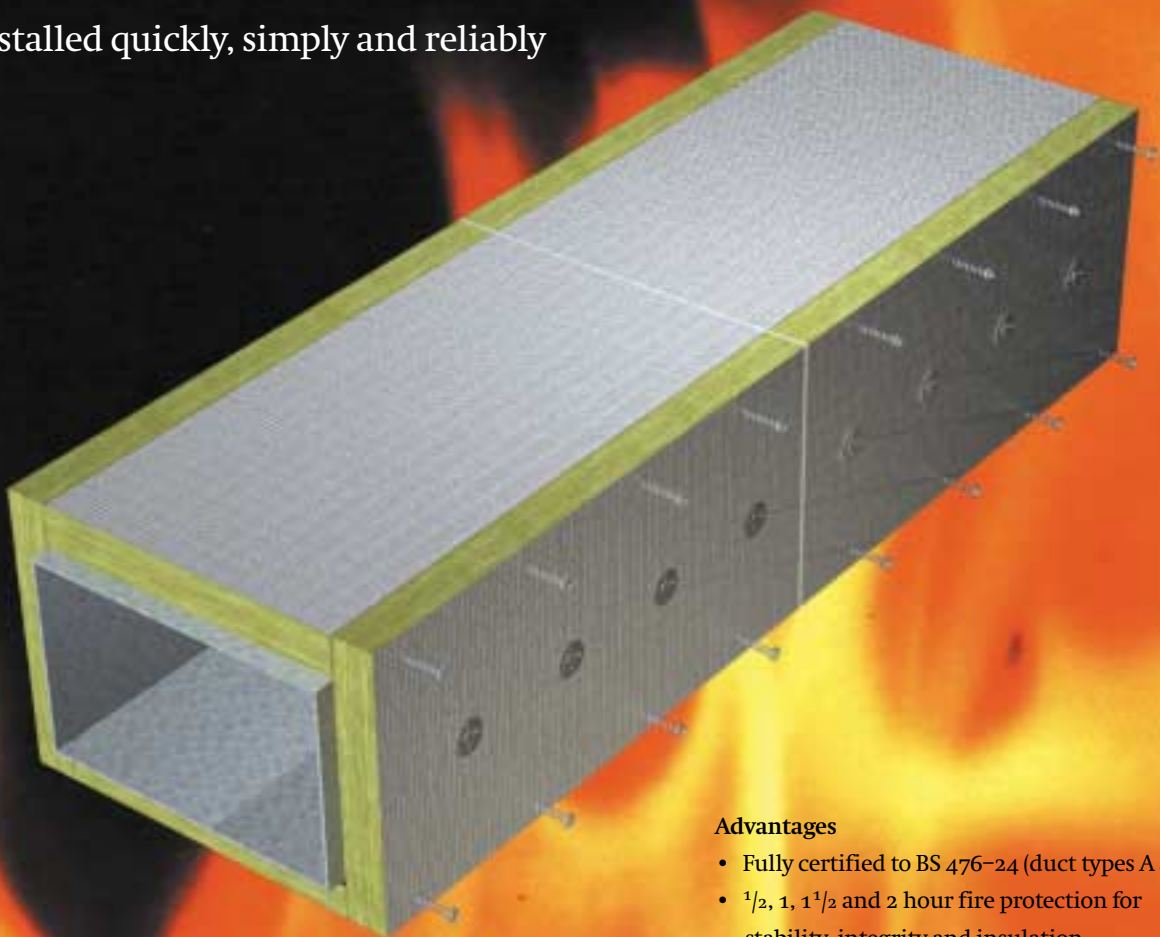

## Advantages

- Fully certified to BS 476-24 (duct types A and B)
- 1/2, 1, 1 1/2 and 2 hour fire protection for stability, integrity and insulation
- Choice of fixing options
- Single layer, enabling verification of system installation
- Space efficient, non-brittle, strong and safe
- Multi-role insulation: fire protection, acoustic and thermal

**Contents** System options 2 • Standards and regulations 2 • Circular and oval ducts 3 • Product properties 4  
Fire protection thicknesses 4 • Hangers, bearers and flanges 4 • Ancillaries and fixings 5 • Wall penetrations 6  
Two and three-sided applications and elbows 6 • Access hatches 6 • Criteria for ductwork 7 • Typical specification clauses 8

## Conlit Ductwork System – overview and standards

### System description

Manufactured from Rockwool mineral wool, Conlit Ductwork products provide fire protection and thermal and acoustic insulation for circular and rectangular steel ductwork.

The simplicity and flexibility of fixing options ensure rapid and reliable installation to both vertical and horizontal duct systems.

Three products are available in the Conlit Ductwork range:-

*Conlit Ductwork Slab* – for rectangular ducts (orange panel opposite).

*Conlit Ductwork Section* – for circular ducts between 17 mm and 610 mm diameter (page 3, opposite).

*Conlit Ductwork PSM* – for circular ducts greater than 406 mm diameter (page 3, opposite)

All three Conlit Ductwork products are supplied faced on one side with reinforced aluminium foil.

Full product descriptions and available sizes are given on page 4.

### The requirements for ductwork fire protection

Three performance criteria; stability, integrity and insulation, are required in equal measure for all ducts which pass through fire-rated walls or floors.

BS 5588 – 9, Clause 6.2.5.3 requires that, for fire-resisting ductwork:

*The fire resistance of the ductwork, when tested from either side, should not be less than the fire resistance required for the elements of construction in the area through which it passes'*

BS 476 – 24, Clause 9.1 states that:

*The fire resistance of test specimens shall be the duration in minutes, of heating in accordance with 5.1.1 until failure occurs according to one or more of the performance criteria, ie, stability, insulation, integrity, or until the test is terminated, whichever is the shortest time'*

### Conlit Ductwork System test data

The Rockwool Conlit Ductwork System has been tested and assessed by BRE LPC in accordance with BS 476 – 24. 'Fire tests on building materials and structures – Methods for determination of the fire resistance of ventilation ducts'.

The Conlit Ductwork System can be used to provide fire protection to horizontal, vertical, rectangular, circular, ventilation and smoke extract steel ductwork fully in accordance with BS 476 – 24, ducts 'Type A' and 'Type B', "Fire break out" and "Fire break in".

The 1/2, 1, 1 1/2, and 2 hour periods of fire resistance stated in this manual are for stability, integrity and insulation in equal measure. For example, the 60 minutes duct constructions shown are certified for 60 mins stability, 60 mins integrity and 60 mins insulation .

#### 'Kitchen extract' ducts

These are subject to separate BS 476-24 requirements, and are additionally covered for 1/2 and 1 hour protection periods.

## System options-rectangular ducts

### Mitre-joint fixing methods

The use of mitre-joints at slab corners allows installation in situations where welding may not be practicable.

Nails are generally spaced at 500 mm maximum centres (see page 5).

See 'Fire resistance' table on page 4 for limitations on duct sizes.

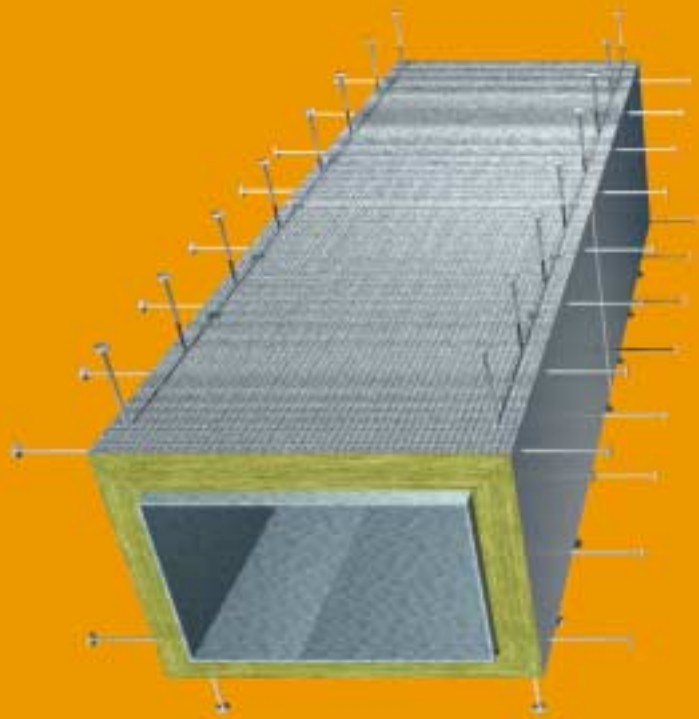

### Mitre-joint method

All joints bonded with Conlit Glue. Longitudinal corner joints secured with nails while Conlit Glue cures.

**Welded pin fixing methods**

Attachment by welded pins allows extremely rapid installation with slab joints simply butted together.

Welded pins are generally spaced at 350 mm maximum centres along the length of the duct and at at 500 mm maximum centres across the width and depth of the duct. Pins are required on all four sides of vertical ducts, but may be omitted from the top face of horizontal ducts (see page 5).

**Welded pin method 1**

Longitudinal corner joints fixed with pigtail screws at 250 mm maximum centres (screw length to be 2 x slab thickness). Side wall slabs must overlap top and bottom slabs (as shown). Cross joints bonded with Conlit Glue.

**Welded pin method 2**

All joints bonded with Conlit Glue. Slabs may overlap in either direction.

**Welded pin method 3**

Longitudinal corner joints fixed with pigtail screws at 250 mm maximum centres (screw length to be 2 x slab thickness). Side wall slabs must overlap top and bottom slabs (as shown). Cross joints protected with centrally positioned 100 mm wide Conlit cover strips. Strips fixed with pigtail screws at 250 mm maximum centres along both long edges.

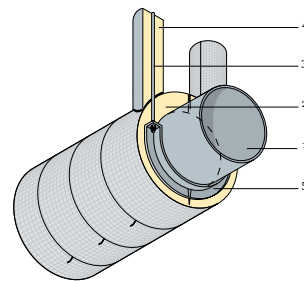
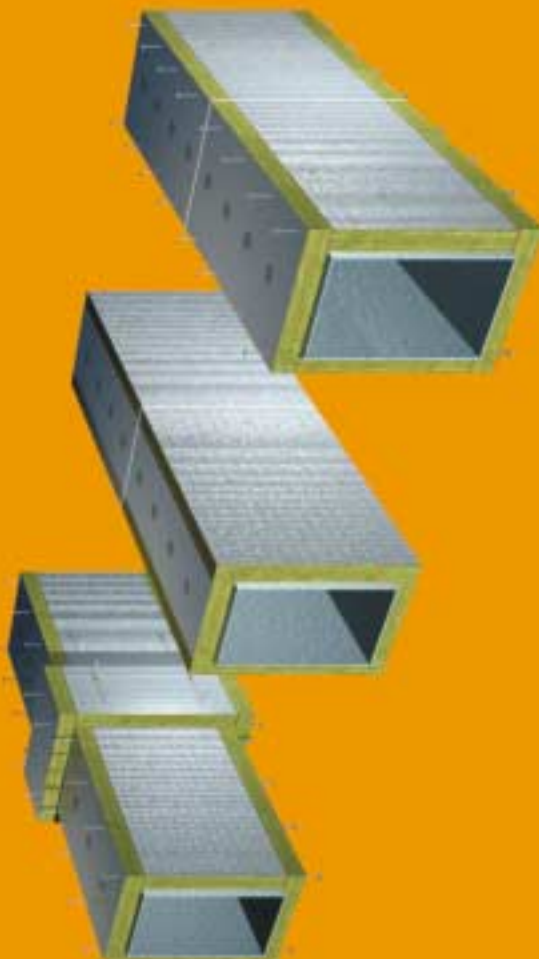

Figure 1 Conlit Ductwork Section applied to circular duct

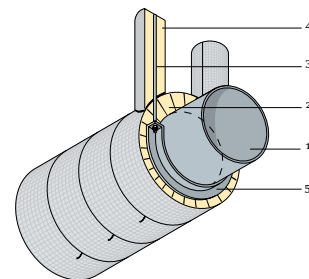

Figure 2 Conlit Ductwork PSM applied to circular duct

**Notes to Figures 1 and 2**

- 1 Circular steel duct to DW/144
- 2 Conlit Ductwork Section/ Conlit Ductwork PSM
- 3 M10 steel drop rods at 1500 mm maximum centres
- 4 Conlit Ductwork Slab/Section - protection to hanger system
- 5 30 x 30 x 3 mm minimum steel angle bearer

**Conlit Ductwork Section**

Circular steel ducts of between 17 mm and 610 mm diameter may be protected using Conlit Ductwork Section.

Conlit Ductwork Section must be glued with Conlit Glue at the joints and in the grooves. Steel bands or wires must be fitted circumferentially to the system at 300 mm nominal centres to hold all joints and grooves tightly closed while the glue cures.

Where required, cover strips and bearer protection pieces are to be cut from Conlit Ductwork Section (or Ductwork PSM) of the appropriate diameter. The foil covering is to be removed from the area of Conlit Ductwork Section immediately beneath the cover strips prior to gluing into position and securing with steel nails or pins.

Self adhesive aluminium foil tape may be used to seal the joints where a vapour barrier is required.

The hanger system is as described on page 7, with the angle bearer formed into a circular shape to suit the diameter of the duct or the Conlit Ductwork Section (depending on whether the hanger is located inside or outside the protection).

Conlit Ductwork Section is used to protect the drop rods as described on page 7. General installation principles are as otherwise described in this manual for Conlit Ductwork Slab.

**Conlit Ductwork PSM**

Circular steel ducts of 406 mm and greater diameter may also be protected using Conlit Ductwork PSM.

Conlit Ductwork PSM must be glued at the joints and in the grooves with Conlit Glue. Steel bands or wires must be fitted circumferentially to the system at 300 mm nominal centres to hold all joints and grooves tightly closed while the glue cures.

General duct, hanger and installation details are as described for Conlit Ductwork Section.

## Product properties and fire resistance data

### Product descriptions

#### Conlit Ductwork Slab

- Size: 1200 × 1800 mm
- Thicknesses: 25, 30, 40, 50, 70, 90 mm
- Facing: reinforced aluminium foil
- Surface spread of flame: Class 1 to BS 476-7
- Non-combustibility: ISO 1182
- Thermal conductivity: 0.035 W/mK at 10 °C

#### Conlit Ductwork Section

Diameters: 17 to 610 mm

Thicknesses: 25 to 90 mm\*

Facing: reinforced aluminium foil

#### Conlit Ductwork PSM

Conlit Ductwork PSM is made of Conlit Ductwork Slab with factory machined grooves to suit specific duct diameters.

Diameters: 406 mm and above

Thicknesses: 40, 50, 70, 90 mm\*

Facing: reinforced aluminium foil

\* Some thicknesses of Conlit Ductwork Section and Ductwork PSM are not available for certain duct diameters.

### Fire resistance

#### Performance summary – Conlit Ductwork Slab, Section and PSM

Fire resistance (hours)	Duct type	Required Conlit thickness (mm)	Joint options (see Fig. 3 below)	Hanger protection		Max. duct size for mitre-joint, glued system (mm)
				Conlit Ductwork Slab (mm)	Conlit Ductwork Section (mm)	
1/2	Vertical	25	C	30	17 × 30	1000 × 1000
	Horizontal	25	C	30	17 × 30	1000 × 1000
	Kitchen extract	40	B C	30	17 × 30	1500 × 1500
1	Vertical	30	C	40	17 × 40	1000 × 1000
	Horizontal	40	B C	40	17 × 40	1500 × 1500
	Kitchen extract	90	A B C	40	17 × 40	1500 × 1500
1 1/2	Vertical	50	B C	50	17 × 50	1500 × 1500
	Horizontal	70	A B C	50	17 × 50	1200 × 1200
2	Vertical	70	A B C	60	17 × 60	1500 × 1500
	Horizontal	90	A B C	60	17 × 60	1000 × 1000

Protection of bearers by Conlit Ductwork Slab, Ductwork PSM or Ductwork Section

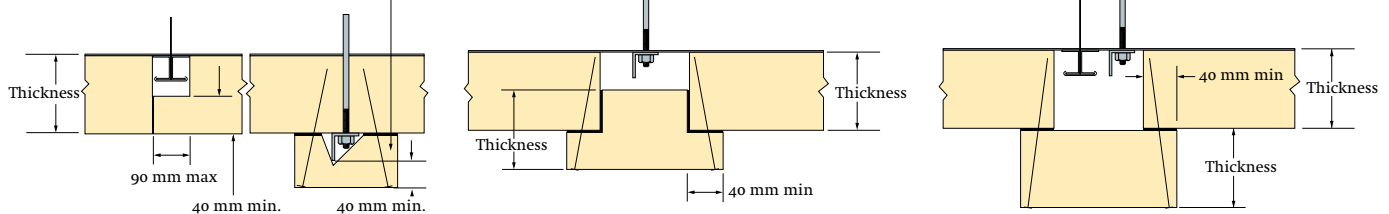

Figure 3 Joint Option A – Rebated protection

Joint Option B – Protection using 'T' section

Joint Option C – Protection using block cover strip

## Hangers, bearers and flanges

### Installation methods

The Rockwool Conlit Ductwork System is approved to provide fire protection to steel ductwork, wholly constructed using steel fixings in accordance with current HVCA specification DW/144 and superseded specification DW/142.

Where there are constructional options within DW/144 and DW/142, these are expanded upon below. These details are primarily concerned with duct joint types and the suspension method.

DW/142 flanged cross joint types J3, J4, J5 and J6 are acceptable for use with the Conlit Ductwork System, without modification. For joint types J1 and J2, please contact Rockwool for advice.

#### Dimensions

Item	Duct size (mm)		
	Up to 1500 × 1500	Up to 2000 × 2000	Up to 3000 × 3000*
Maximum hanger centres (mm)	1500	1500	1500
Minimum drop rod size	M10	M10	M12
Minimum angle bearer (mm)	30 × 30 × 3	50 × 50 × 5	50 × 50 × 6

\* DW/144 and DW/142 do not specifically cover ducts larger than 3 m wide. Please contact Rockwool for details.

Conlit Ductwork Slab, Ductwork Section or Ductwork PSM may be installed either outside or inside the hanger system.

Bearers will require additional protection only when positioned outside the Conlit Ductwork layer.

Drop rods will normally be protected with Conlit Ductwork Section or with Conlit Ductwork Slab blocks (see Figure 4).

Alternatively, the support steelwork may be sized so that separate protection is not required. Design of this 'unprotected support' method is independent of the Conlit Ductwork System.

#### Protection of hangers outside Conlit Ductwork System

Hangers outside the Conlit Ductwork System are protected by cutting a rebate into a block of Conlit Ductwork Slab, Ductwork PSM or Ductwork Section.

The rebate should be no larger than necessary to accommodate the bearer. The block should be glued and pinned in position (see Figure 3, Option A) or secured using pigtail screws.

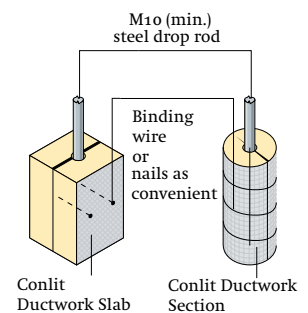

Figure 4 Isometric view of drop rod protection options

## Ancillaries

### Welded steel pins

Welded pins are generally spaced at 350 mm maximum centres along the length of the duct and at 500 mm maximum centres across the width and depth of the duct. Pins are required on all four sides of vertical ducts, but may be omitted from the top face of horizontal ducts (see Figures 5 and 6).

Details of alternative mechanically fixed pins are available from Rockwool on request.

### Conlit Glue

Conlit Glue has a pH value of 11. It is provided in 17 kg drums and should always be stirred before use.

Where required, 1–1.5 mm of glue should be applied to each Conlit joint. The glue is generally applied by spatula or trowel.

Where present, any foil facing must be removed from surfaces prior to the application of Conlit Glue.

### Nails (for use only with mitre-joint 'glued' systems)

The nail length is to be  $2 \times$  board thickness (see Figure 7 for positions).

### Pigtail screws

Pigtail screws are to be used at all corner joints where Conlit Glue is not used, and to secure cross joint cover strips.

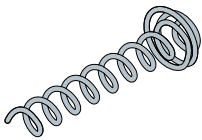

Pigtail screws are to be positioned at 250 mm maximum centres, and the screw length is to be  $2 \times$  slab thickness.

For horizontal ducts, pigtail screws must be inserted horizontally, as shown on pages 2 and 3.

### Optional edge protection

Light gauge metal angles may be glued in position to provide optional edge protection. The metal angles must be de-greased. Small pins may be required to hold the angle to the underside of the duct.

### Vapour barrier

Where a vapour barrier is required, all exposed Conlit edges and penetrations through the foil must be sealed using aluminium foil tape.

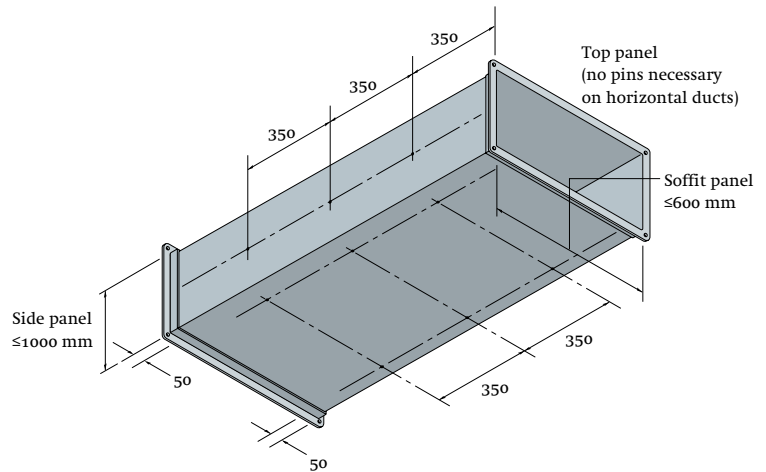

Figure 5 Steel pin arrangement where side panel does not exceed 1000 mm and soffit panel does not exceed 600 mm

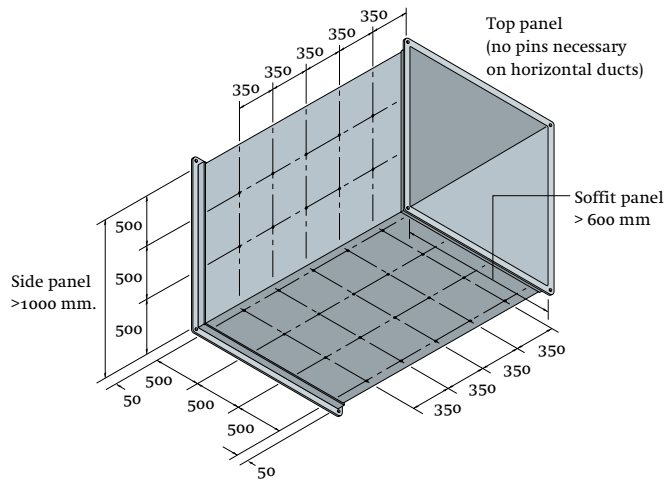

Figure 6 Steel pin arrangement where side panel is greater than 1000 mm or soffit panel is greater than 600 mm

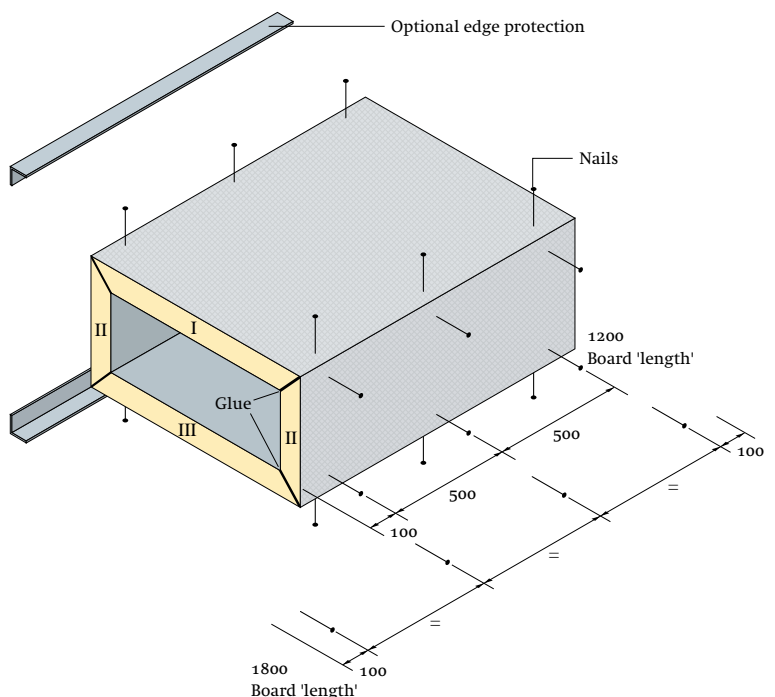

Figure 7 Rectangular ducts - 45° mitre joint system, showing installation sequence

## Wall penetrations, elbows, 2 and 3-sided applications and access hatches

### Wall and floor penetrations

Support to duct sides is required at all penetrations for stability purposes. This support can be provided by:

- a  $30 \times 30 \times 2$  mm mild steel angle frame fixed to the duct at the penetration mid point. Steel rivets should be used at 300 mm maximum centres (Figure 8),
- b locating the duct joint at the penetration mid point.

In all cases, low density Rockwool (typically RW2) is packed tightly into the void between the Conlit and the wall opening.

120 mm wide blocks of Conlit are glued (or secured with pigtail screws) to the duct insulation and to the wall on both sides of the penetration.

All Conlit to wall joints are glued. Aluminium foil is located in Conlit joints at wall penetrations (as shown).

### Proprietary penetration seals

Where proprietary penetration seals are used, compatibility with the separating element, duct construction and Conlit Ductwork System must be demonstrated by independent test or assessment.

### Elbows (rectangular ducts)

Small elbows may simply be boxed or 'squared off'. Larger elbows may need to be protected by cutting fan shaped pieces, generally in accordance with the illustration (Figure 9).

### Two and three-sided applications (rectangular ducts)

The use of Conlit Ductwork Systems incorporating welded pins is recommended for 2 and 3-sided applications.

The method illustrated (Figure 10) for three-sided applications, may also be used for two-sided applications where the duct is securely braced in the corner of a room.

### Access hatches (rectangular ducts)

Steel access hatches which are constructed and fitted in accordance with DW144 may be protected with Conlit Ductwork Slab (figure 11).

The Conlit cover may be fitted in any face of the duct. However, if the sliding cover is not in the horizontal plane the guides must be positioned so as to prevent movement of the cover due to weight, vibration etc.

The sliding cover must be a tight fit in the guides. No part of the arrangement may be within 50 mm of edges or joints within the main duct protection layer of Conlit Ductwork Slab.

All Conlit Ductwork Slab joints (excluding sliding joints) are to be glued and pinned as previously detailed.

### Access hatches (circular ducts)

Details of access hatches for circular ducts are available on request.

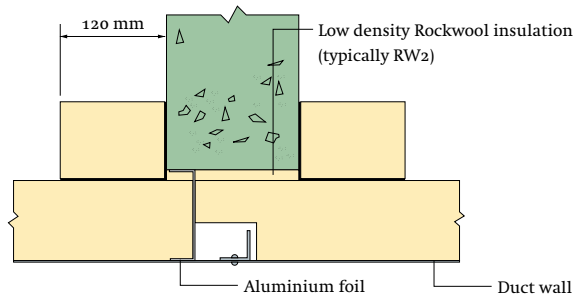

Figure 8 Steel angle frame support to duct at penetration mid point

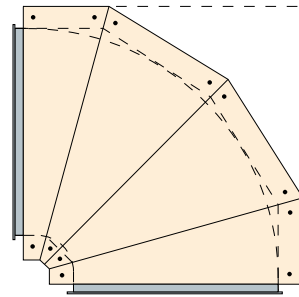

Figure 9 Typical elbow detail for rectangular ducts

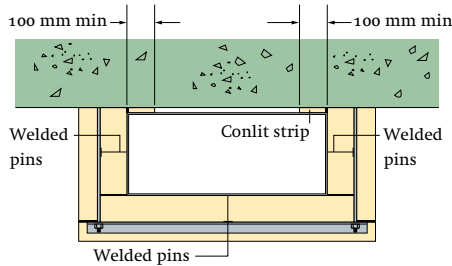

Figure 10 Three sided protection for rectangular ducts, using welded pin fixing method

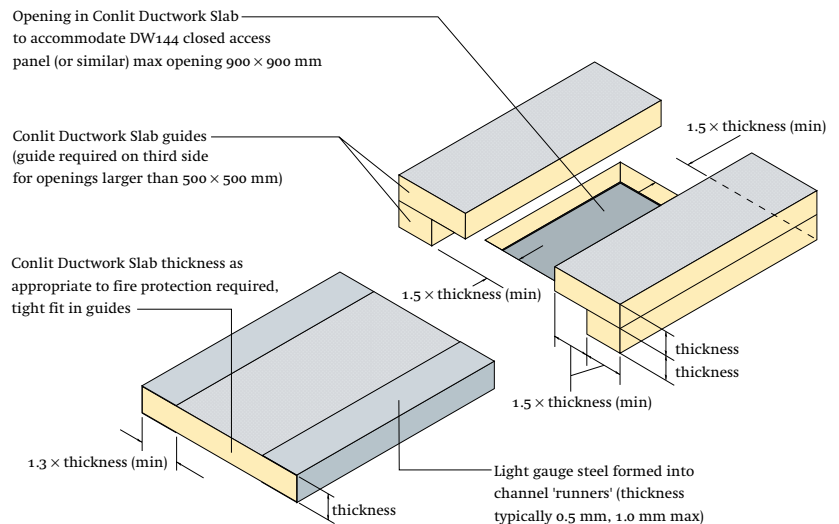

Figure 11 Removable cover panel for steel access hatch

## Criteria for preparation of ductwork prior to insulation

The Conlit Ductwork System is certified to provide fire protection to ductwork conforming to Construction Details 1 to 12 in the table below and to the requirements of HVCA Specification DW/144. The table may be used as a check list for on-site verification of ductwork construction.

Project reference				
Job location				
	Construction detail	Requirement	Within specification?	Details of modification where needed
1	Duct sheeting	Rigid steel (zinc-coated, alu-zinc coated, black or stainless).		
2	Sheet thickness	0.8 mm or greater. See DW/144 for ducts larger than 1500 mm.		
3	Maximum duct size			
3a	Welded pin fixing methods	<p>Up to 1500 mm × 1500 mm: no additional system modifications.</p> <p>Up to 2000 mm × 2000 mm: increase angle bearer size to 50 × 50 × 5 mm min.</p> <p>Up to 3000 mm × 3000 mm: increase angle bearer size to 50 × 50 × 6 mm min.</p> <p>Increase drop rod diameter to M12 min.</p> <p>Up to 4000 mm × 4000 mm: 50 × 50 × 6 mm min. bearer. M12 min. drop rod.</p> <p>Incorporate additional drop rod mid-width through duct and bearer*.</p> <p>Weld (or fasten with nuts and large washers) M15 min. strengthening rod. at mid-width of each flanged joint and penetration point to maintain cross section.</p> <p>Seal all holes with mastic.</p> <p>Above 4000 mm × 4000 mm: 50 × 50 × 6 mm bearer. M12 min. drop rod.</p> <p>Incorporate additional drop rods through duct and bearer to ensure 2000 mm max. spacing along bearer*. Weld (or fasten with nuts and large washers) M15 min. strengthening rod at each flanged joint and penetration point to ensure 2000 mm max. spacing along joint. Seal all holes with mastic.</p> <p>*Additional drop rods to pass through duct and bearer. Rods to support bearer.</p> <p>*Top' of duct to be held in position with steel nuts and large steel washers.</p>		
3b	Mitre-joint fixing methods			
	1/2 hr vertical duct	1000 mm × 1000 mm		If duct dimensions exceed those shown, use welded steel pins as per Conlit Ductwork System manual (see item 3a.)
	1/2 hr horizontal duct	1000 mm × 1000 mm		
	1/2 hr kitchen extract	1500 mm × 1500 mm		
	1 hr vertical duct	1000 mm × 1000 mm		
	1 hr horizontal duct	1500 mm × 1500 mm		
	1 hr kitchen extract	1500 mm × 1500 mm		
	1 1/2 hr vertical duct	1500 mm × 1500 mm		
	1 1/2 hr horizontal duct	1200 mm × 1200 mm		
	2 hr vertical duct	1500 mm × 1500 mm		
	2 hr horizontal duct	1000 mm × 1000 mm		
4	Flanged cross joint	Type J3, J4, J5 or J6 to HVCA specification DW/142.		Strengthen joints (contact Rockwool)
5	Joint seal	May be included or omitted.		
6	Constructional fixings	Steel		
7	Bearers	30 × 30 × 3 mm (min.) steel angle. See item 3a for ducts larger than 1500 mm.		
8	Drop rods	M10 (min.) mild steel. See item 3a for ducts larger than 2000 mm.		
9	Drop rod anchors			
	Fixed through steel suspension frame	Steel frame to be independently fire rated.		Fire protect steelwork.
	Fixed into concrete	Anchors to have confirmed fire rating.		If fire rating is unconfirmed and anchor is all-steel, ie without plastic or chemical components; affix 300 mm × 300 mm collar of unfaced Conlit Ductwork Slab to soffit with Conlit Glue, keeping anchor central. Collar thickness to equal duct encasement layer. Optional self-tapping screws may be used to support collar. Glue adjacent Conlit drop rod protection to collar.
10	Spacing of suspension system			
10a	Horizontal ducts	1500 mm max centres.		Install additional supports
10b	Vertical ducts: 2 or 3 sided protection	1500 mm max centres.		
10c	Vertical ducts: 4 sided protection	Support at every floor (4 m max centres)		
11	Stiffening of duct at penetration detail	Duct flange or 30 × 30 × 3 mm steel angle frame fixed with steel fixings at 300 mm max. centres. To be positioned within the width of the penetration. See item 3a for ducts larger than 3000 mm.		Install steel angle frame.
12	Compartment wall	Fire rated masonry, concrete, brick, block, plasterboard or other fire rated construction.		

# Typical specification clauses

Typical specification clauses for rectangular ducts to be read in conjunction with System options on pages 2–3

## Mitre-joint fixing method

- 1 All ductwork is to be insulated with .....\* mm Rockwool Conlit Ductwork Slab, having a factory applied reinforced aluminium foil to one face and complying with Building Regulations Class 'O' requirements.
- 2 The Conlit joints at ductwork corners are to be 45° mitred. Square butt joints to be used elsewhere.
- 3 The foil facing is to be removed from any surfaces to which Conlit Glue is to be applied.
- 4 All joints are to be filled with Conlit Glue and held tightly closed.
- 5 All mitred joints are to be held tightly closed with nails (length = approx. 2 × Conlit Ductwork Slab thickness) until the glue has fully cured. 2 nails juxtaposed at 90° are to be located at 3 points per 1200 mm length of mitred joint and at 4 points per 1800 mm length.
- 6 Drop rods and bearers are to be at 1500 mm maximum centres and to be M10 steel rod and 30 × 30 × 3 mm steel angle respectively. Ductwork is to be generally in accordance with HVCA Specification DW/144.
- 7 All drop rods and exposed bearers are to be insulated with .....\* mm Conlit Ductwork Slab or .....† × .....\* mm Conlit Ductwork Section, as appropriate. Rebates or cover pieces are to be used at duct flange and bearer locations according to site conditions and subject to Rockwool approval.
- 8 Where a vapour barrier is required, all exposed Conlit edges and penetrations through the foil should be sealed using soft self-adhesive aluminium foil tape.

## Welded pin fixing method 1

- 1 All ductwork is to be insulated with .....\* mm Rockwool Conlit Ductwork Slab, having a factory applied reinforced aluminium foil to one face and complying with Building Regulations Class 'O' requirements.
- 2 The Conlit Ductwork Slab is to be affixed to the duct using 2.5 mm diameter welded steel pins and 38 mm spring steel washers in accordance with the Rockwool manual 'Conlit Ductwork System'.
- 3 The foil facing is to be removed from any surfaces to which Conlit Glue is to be applied.
- 4 All corner joints are to be fixed with pigtail screws at 250 mm maximum centres. Screw length is to be 2 × slab thickness.
- 5 All cross joints are to be filled with Conlit Glue and held tightly closed.
- 6 Drop rods and bearers are to be at 1500 mm maximum centres and to be M10 steel rod and 30 × 30 × 3 mm steel angle respectively. Ductwork is to be generally in accordance with HVCA Specification DW/144.
- 7 Drop rods and exposed bearers are to be insulated with .....\* mm Conlit Ductwork Slab or .....† × .....\* mm Conlit Ductwork Section, as appropriate. Rebates or cover pieces are to be used at duct flange and bearer locations according to site conditions and subject to Rockwool approval.
- 8 Where a vapour barrier is required, all exposed Conlit edges and penetrations through the foil should be sealed using soft self-adhesive aluminium foil tape.

## Welded pin fixing method 2

Delete clauses 3 and 5 in Method 1 above, and insert new clause 5:

- 5 All joints are to be filled with Conlit Glue and held tightly closed. If necessary, nails may be used at corner joints to aid this process.

## Welded pin fixing method 3

Delete clauses 3 and 5 in Method 1 above, and insert new clause 5:

- 5 All cross joints are to be covered with centrally positioned 100 mm wide strips of Conlit Ductwork Slab of the same thickness as the insulation. The cover strips are to be fixed along both edges using pigtail screws, as described above.

\* Insert Conlit Ductwork Slab insulation thickness required.

† Insert appropriate overall diameter.

Rockwool Limited reserves the right to alter or amend the specification of products without notice as our policy is one of constant improvement.

The information contained in this data sheet is believed to be correct at the date of publication. Whilst Rockwool will endeavour to keep its publications up to date, readers will appreciate that between publications there may be pertinent changes in the law, or other developments affecting the accuracy of the information contained in this data sheet.

The above applications do not necessarily represent an exhaustive list of applications for the Conlit Ductwork System. Rockwool Limited does not accept responsibility for the consequences of using the Conlit Ductwork System in applications different from those described above. Expert advice should be sought where such different applications are contemplated, or where the extent of any listed application is in doubt.

# Sitework, health and safety

## Sitework

### Handling

The Conlit Ductwork range of products is light and easy to handle and fix. The products can be cut and shaped using knives, saws, etc.

## Health and safety

A COSHH Data sheet is available from Rockwool's Marketing Services Department.

Current HSE 'CHIP' Regulations and EU Directive 97/69/EC confirm that Rockwool fibres are not classified as a possible carcinogen.

**WILHAMS**

Wilhams Insulation Far East Sdn Bhd (340166M)  
15 & 17 Jalan U5/23, Seksyen U5,  
Mah Sing Integrated Industrial Park  
40150 Shah Alam, Selangor Darul Ehsan, Malaysia  
Tel: 603-7846 6728 Fax: 603-7846 6540  
E-mail: wfe@tm.net.my